

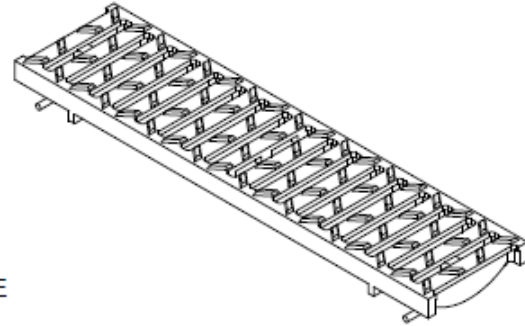

1-877-903-7246

Number 153095	Series CPS604 F Class Ductile Iron Grate
------------------------------------	--

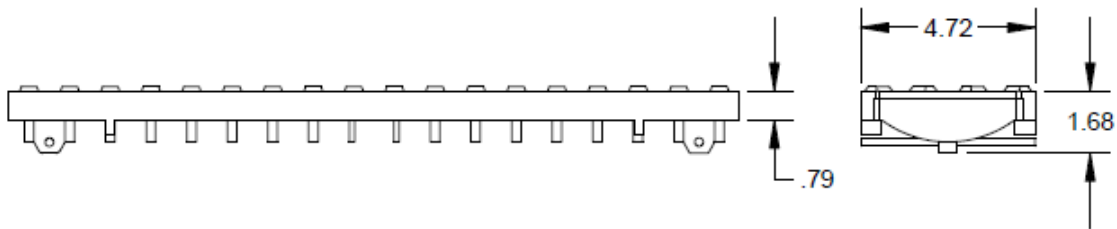
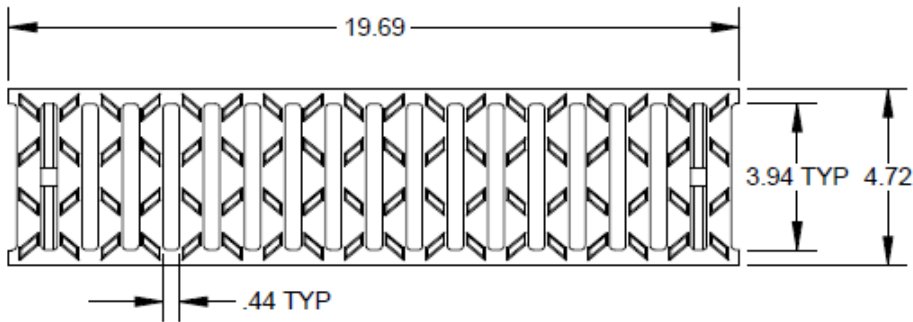

NOTE:
FREE AREA IS 30.7 SQ. IN. PER 1/2 METER GRATE



Manufacturer  Quality engineered trench drain system	Specification MEA-JOSAM DUCTILE IRON GRATE WITH PROFIX SECURING FEATURE. FITS 100 AND 1000 SERIES CHANNELS. MEETS LOAD CLASS F. SUPPLIED BY TRENCH DRAIN SUPPLY.
--	--

DISCLAIMER - The customer and the customer's architects, engineers, consultants, and other professionals are completely responsible for the selection installation and maintenance of any product purchased from Trench Drain Supply and/or its manufacturers. TRENCH DRAIN SUPPLY MAKES NO WARRANTY, EXPRESS OR IMPLIED, AS TO THE SUITABILITY, DESIGN, MERCHANTABILITY, OR FITNESS OF THE PRODUCT FOR CUSTOMERS APPLICATION. The drawing and information provided remain the property and copyright of the manufacturer listed. The manufacturer reserves the right to modify specification without notice.